



# PARTS CATALOG

Published

2010/12 (Dec.)

---

0CNP2-G87900

## Directions for the Parts Catalog.

- The parts stipulated in this Parts Catalog are not necessarily standard equipped parts.
- Parts may change without prior notice.
- The following is an example of the Parts Catalog format.

OCF10-G21601 29. FUEL INJECTION PUMP(W/BOOST)

REF.	LEV.	PARTS NO.	DESCRIPTION	Q'TY						I	R
				(A)	(B)	(C)	(D)	(E)	(F)		
1	1	729595-51390	FUEL INJECTION PUMP	1	1	1	1	1			1
1-1	1	729595-51391	FUEL INJECTION PUMP	1	1	1	1	1		N	1
		(A=E00185) (B=E00200)									
3	2	26022-060162	SCREW M 6X 16	9	9	9	9	9			
3-1	2	26022-060162	SCREW M 6X 16	4	4	4	4	4		K	
		(A=E00156) (B=E00156) (C=E00156) (D=E00156) (E=E00156)									
4	2	129470-51040	CAMSHAFT	1	1	1	1	1			
5	2	122710-51050	BEARING, ROLLER	2	2	2	2	2			
6	2	129470-51060	RETAINER	1	1	1	1	1			

Remarks

(1) BOOST COMPEMSATOR TYPE. OPTIONAL PART, TO E00155,(4JH-DT, 4JH-DTZ

### ① Ref. No.

The Ref. No. listed may not be in accordance with the illustration Ref. No.

(Ex.) Illustration No.

List Ref No.

1

1

(Before change)

1-1

(After change)

For interchangeable symbols N, R and K, illustrations for new parts may be abbreviated.

### ② Lev. (Level)

Level indication

The numbers below indicate the level of relativity towards the main part.

1 ----- Main parts (Assembly parts)

2 ----- Sub component included in " 1 ".

3 ----- Sub component included in " 2 ".

Note) Parts that are not for sale are partially illustrated but not listed.

### ③ Interchangeability Mark

When a part change takes place, one of the following interchangeability symbols is indicated beside the part.

Symbol	Interchangeability	Contents note
N	Old $\begin{matrix} \leftarrow \text{Yes} \\ \text{No} \rightarrow \end{matrix}$ New	New Part is interchangeable for Old Part but Old Part is not interchangeable for New Part.
Q	Old $\begin{matrix} \leftarrow \text{No} \\ \text{Yes} \rightarrow \end{matrix}$ New	New Part is not interchangeable for Old Part but Old Part is interchangeable for New Part.
R	Old $\begin{matrix} \leftarrow \text{Yes} \\ \text{Yes} \rightarrow \end{matrix}$ New	New/ Old Parts are both interchangeable.
S	Old $\begin{matrix} \leftarrow \text{No} \\ \text{No} \rightarrow \end{matrix}$ New	New/ Old Parts are both not interchangeable.
W		Part newly added.
Z		Part discontinued.
F		Not interchangeable by a single part but interchangeable together with related parts.
K		Changes only for used parts quantities.

### ④ Effective Machine No.

When a part changes, the effective Machine No. will be indicated in the (A)-(F) column.

Product Symbol	Product No.	Product Symbol	Product No.
C	Clutch No. Compressor No.	F	Machine No. (Agricultural Equip.)
D	Drive No.	M	Machine No.
E	Engine No.		

Note 1) A date may follow the symbol. (Ex.) 1996.01

Note 2) "XXXXX" and "ZZZZZ" are for parts that could not be predicted or for engine models that could not be identified.

Note 3) (A=E00185) is the E (Engine Serial Number) for the column (A) model (in this case 4JH-DT) after the parts design change.

### ⑤ Remarks Mark

Figures or alphabets (symbols) are entered in the remarks column.

The comments (remarks) on parts that are indicated at the bottom of the illustration are the same symbols as those stated above.

## PAINTING COLOR

SECTION	PAINTING COLOR	COLOR SPRAY	MAIN PARTS	COLOR CODE (FIGURE)
Main body	<b>YANMAR</b> Red 1	T 0 : R - 9 0 : 4 0 : 0 0 : 0 3	Protection cover CMP	5 0
Main body	<b>YANMAR</b> White	T 0 : R - 9 0 : 2 5 : 0 0 : 0 3	Tire wheel 7 (outer CMP)	1 4
Main body	<b>YANMAR</b> Black	T 0 : R - 9 0 : 2 2 : 0 0 : 0 3	Tilling depth adjustment cover CMP	1 2

Please surely use **YANMAR** Genuine color spray any **YANMAR** agricultural machines.

Given painting color may be altered for improvement, etc. without prior notice.

# CONTENTS

MODEL : MRT6DXPQ ( )  
PC NO : 0CNP2-G87900

Fig.No.	GROUP NAME
	<b>PULLEY &amp; TENSION SECTION</b>
1.	ENGINE MOUNTING
2.	ENGINE & MAIN PULLEYS
3.	TENSION CLUTCH
	<b>TRANSMISSION UNIT</b>
4.	TRANSMISSION CASE
5.	MAIN & COUNTER SHAFTS
6.	FINAL SHAFT
7.	AXLE
8.	DIFFERENTIAL
9.	(SPEED) CHANGE
	<b>WHEEL SECTION</b>
10.	TIRE
	<b>TILLING SECTION</b>
11.	TINE SHAFT & SPADING TINES
12.	TILLING COVER
13.	AUXILIARY COVER
	<b>HANDLE SECTION</b>
14.	HANDLE
15.	HANDLE COVER
16.	CONTROL LEVER
	<b>ENGINE FRAME SECTION</b>
17.	ENGINE FRAME
18.	BELT COVER
19.	BONNET

Fig.No.	GROUP NAME
20.	SKID
	<b>LABELS &amp; ACCESSORIES SECTION</b>
21.	LABELS
22.	TOOLS



Fig.2. ENGINE & MAIN PULLEYS

## 2. ENGINE & MAIN PULLEYS

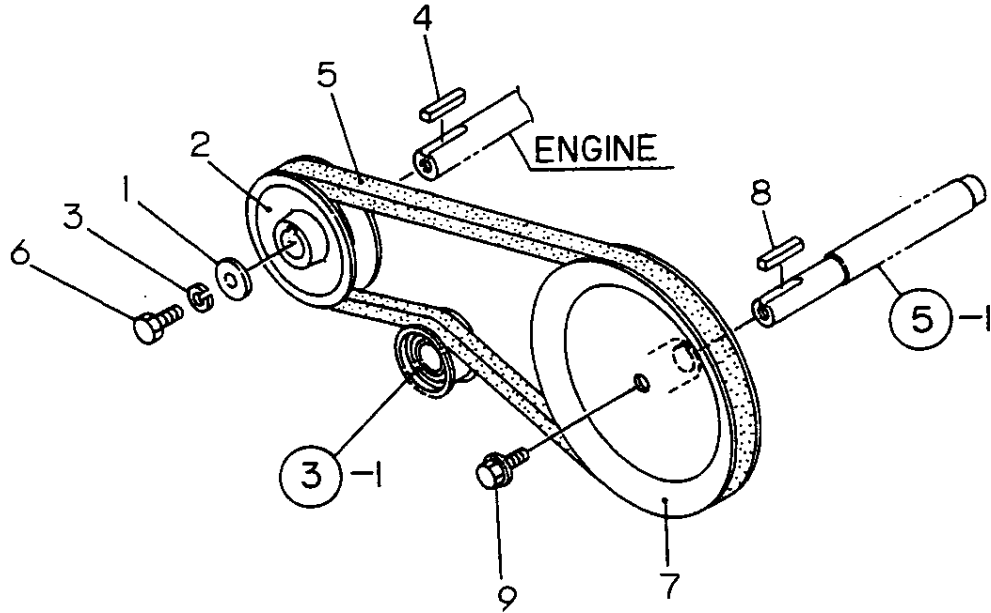

## OCNP2-G87900 2. ENGINE & MAIN PULLEYS

(A)=MRT6DXPQ  
(B)=  
(C)=

(D)=  
(E)=  
(F)=

REF.	LEV.	PARTS NO.	DESCRIPTION	Q'TY						I	R
				(A)	(B)	(C)	(D)	(E)	(F)		
1	1	1D1140-11420	WASHER,PULLEY	1							
2	1	1A2160-12000	V-PULLEY 86B 20	1							
3	1	22217-080000	SPRING WASHER 8	1							
4	1	22512-050300	KEY 5X 30	1							
5	1	1A2170-13400	V-BELT JBX36	1							
5-1	1	1A2171-13400	V-BELT SB36	1							R
(A=*1995.07)											
6	1	26117-080162	BOLT M 8X 16 PLATED	1							
7	1	1A2170-13300	V-PULLEY 160B COMPL.	1							
8	1	1A1105-15200	KEY 5X5X30,FEATHER	1							
9	1	26107-060122	BOLT M 6X 12 PLATED	1							

Fig.3. TENSION CLUTCH

3. TENSION CLUTCH

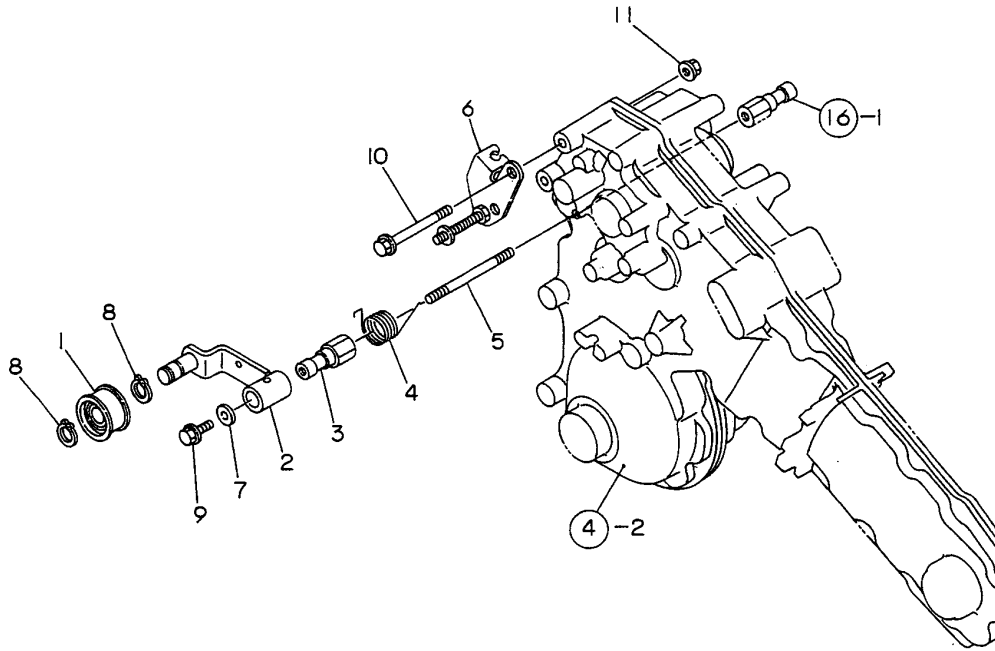

0CNP2-G87900 3. TENSION CLUTCH

(A)=MRT6DXPQ  
(B)=  
(C)=

(D)=  
(E)=  
(F)=

REF.	LEV.	PARTS NO.	DESCRIPTION	Q'TY						I	R
				(A)	(B)	(C)	(D)	(E)	(F)		
1	1	1E4060-10040	ROLLER,TENSION	1							
2	1	1A2170-13000	ARM COMP.,TENSION	1							
3	1	1A2150-13100	TENSION NUT	1							
4	1	1A2120-13120	SPRING,TENSION RETRN	1							
5	1	1A2170-13150	BOLT, TENSION	1							
6	1	1A2170-13600	HOLDER,CABLE	1							
7	1	22137-080000	WASHER 8, POLISHED	1							
8	1	22242-000150	CIRCLIP 15	2							
9	1	26107-080122	BOLT M 8X 12 PLATED	1							
10	1	26107-080802	BOLT M 8X 80 PLATED	2							
11	1	26367-080002	U-NUT M 8	2							

Fig.4. TRANSMISSION CASE

4. TRANSMISSION CASE

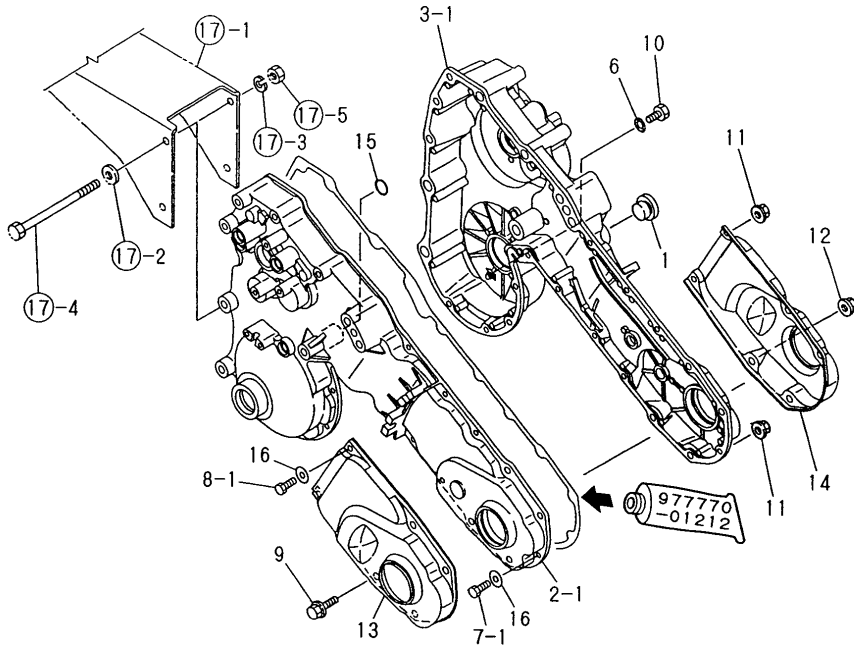

OCNP2-G87900 4. TRANSMISSION CASE

(A)=MRT6DXPQ

(B)=

(C)=

(D)=

(E)=

(F)=

REF.	LEV.	PARTS NO.	DESCRIPTION	QTY						I	R
				(A)	(B)	(C)	(D)	(E)	(F)		
1	1	1A1470-20090	CAP 35,OIL FILLER	1							
2	1	1A2170-21010	CASE L,TRANSMISSION	1							
2-1	1	1A2171-21020	CASE L,TRANSMISSION	1							S
(A=F050555)											
3	1	1A2170-21110	CASE R,TRANSMISSION	1							
3-1	1	1A2171-21120	CASE R,TRANSMISSION	1							S
(A=F050555)											
4	1	1A2170-21150	COVER COMP.,PROTECT.	2							Z
(A=F050555)											
5	1	1A2170-21200	PACKING,TRANSM.CASE	1							Z
(A=F050555)											
6	1	23414-080000	GASKET 8, ROUND	1							
7	1	26106-060202	BOLT M 6X 20 PLATED	10							
7-1	1	1A2171-21300	BOLT M6X20	10							N
(A=F050555)											
8	1	26106-060252	BOLT M 6X 25 PLATED	2							
8-1	1	1A2171-21350	BOLT M6X25	2							N
(A=F050555)											
9	1	26107-080252	BOLT M 8X 25 PLATED	2							
10	1	26117-080122	BOLT M 8X 12 PLATED	1							
10-1	1	1A2001-21250	BOLT M8X12,COLLAR HD	1							S
(A=F039621)											
10-2	1	26117-080122	BOLT M 8X 12 PLATED	1							S
(A=F050555)											
11	1	26367-060002	NUT M 6	12							
12	1	26367-080002	U-NUT M 8	2							
13	1	1A2170-21250	COVER L CMP.,PROTEC.	1							W
(A=F050555)											
14	1	1A2170-21260	COVER R CMP.,PROTEC.	1							W
(A=F050555)											
15	1	24341-000180	O-RING 1A S-18.0	1							W
(A=FXXX)											
16	1	22137-060000	WASHER 6, POLISHED	12							W
(A=F050555)											

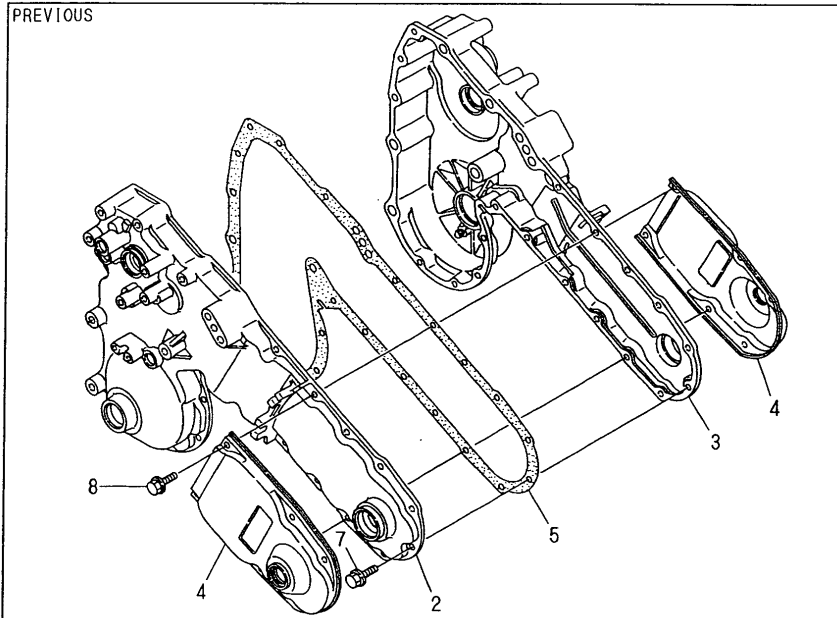
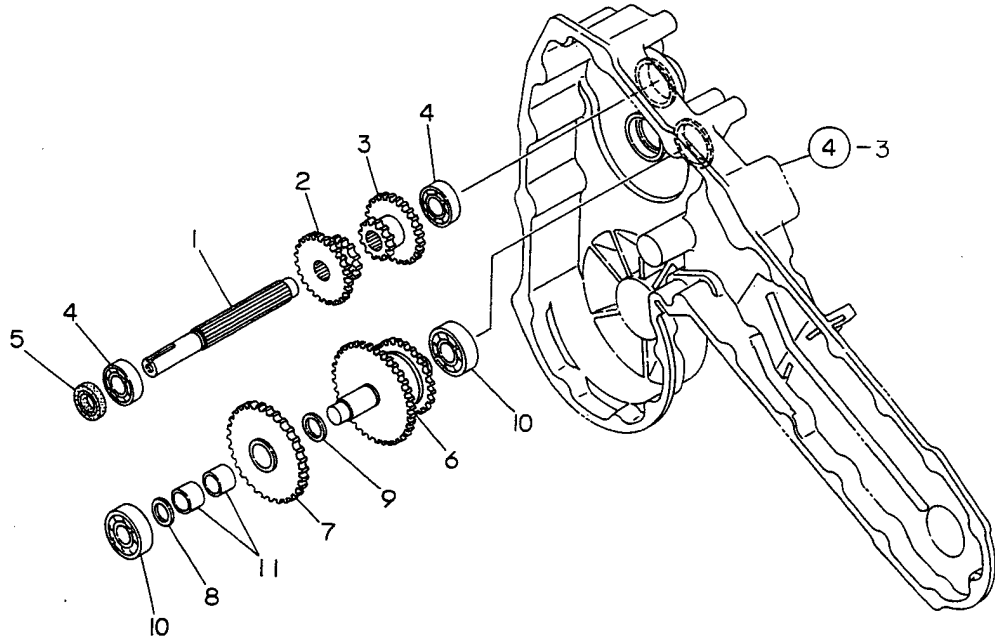



Fig.5. MAIN & COUNTER SHAFTS

5. MAIN & COUNTER SHAFTS



0CNP2-G87900 5. MAIN & COUNTER SHAFTS

(A)=MRT6DXPQ  
(B)=  
(C)=

(D)=  
(E)=  
(F)=

REF.	LEV.	PARTS NO.	DESCRIPTION	QTY						I	R
				(A)	(B)	(C)	(D)	(E)	(F)		
1	1	1A2170-23000	MIN SHAFT	1							
1-1	1	1A2171-23050	SHAFT, MAIN	1							S
(A=F050555)											
2	1	1A2170-23011	GEAR 11X28	1							
3	1	1A2170-23021	GEAR 15X30	1							
4	1	24101-062024	BALL BEARING	2							
5	1	24421-153007	SEAL TC15 30 07, OIL	1							
6	1	1A2170-23101	COUNTERSHAFT COMPL.	1							
6-1	1	1A2170-23102	COUNTERSHAFT COMPL.	1							S
(A=F050555)											
7	1	1A2170-23141	GEAR 28X9 COMPL.	1							
8	1	1A1735-23250	SPACER 15X24X1.0	1							
8-1	1	1A2170-23170	COLLAR 17X25X6	1							S
(A=F050555)											
9	1	1E4060-74090	LINER 17X24X1	1							
10	1	1A2000-23251	BEARING 6302-9T3C	2							
11	1	24161-172115	NEEDLE 172115	2							

Fig.6. FINAL SHAFT

6. FINAL SHAFT

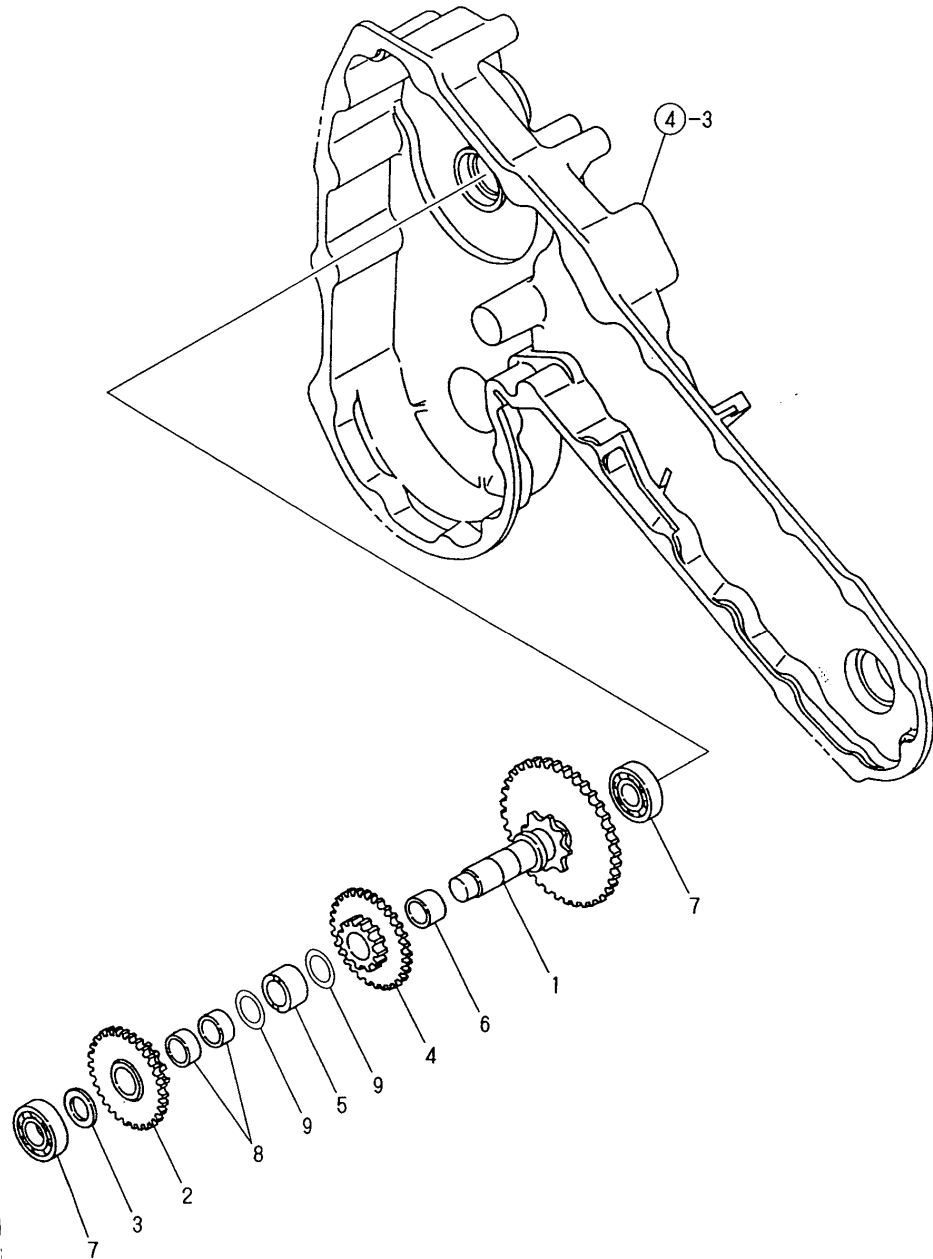

0CNP2-G87900 6. FINAL SHAFT

(A)=MRT6DXPQ  
(B)=  
(C)=

(D)=  
(E)=  
(F)=

REF.	LEV.	PARTS NO.	DESCRIPTION	QTY						I	R
				(A)	(B)	(C)	(D)	(E)	(F)		
1	1	1A2170-23200	SHAFT COMPL.,FINAL	1							
1-1	1	1A2170-23201	END-SHAFT	1							S
(A=F050555)											
2	1	1A2170-23231	GEAR 31X11 COMPL.	1							
3	1	1A1735-23250	SPACER 15X24X1.0	1							
4	1	1A2170-23261	GEAR 15X30 COMPL.	1							
5	1	1A2170-23280	COLLAR 17X25X15.5	1							
(A=F050555)											
5-1	1	1A2170-23282	COLLAR 17X24X13.5	1							S
(A=F050555)											
6	1	1A2170-23290	BUSH 17X15	1							
7	1	24101-062024	BALL BEARING	2							
8	1	24161-172110	NEEDLE BERG. #172110	2							
9	1	1E4060-74090	LINER 17X24X1	2							W
(A=F050555)											

Fig.7. AXLE

7. AXLE

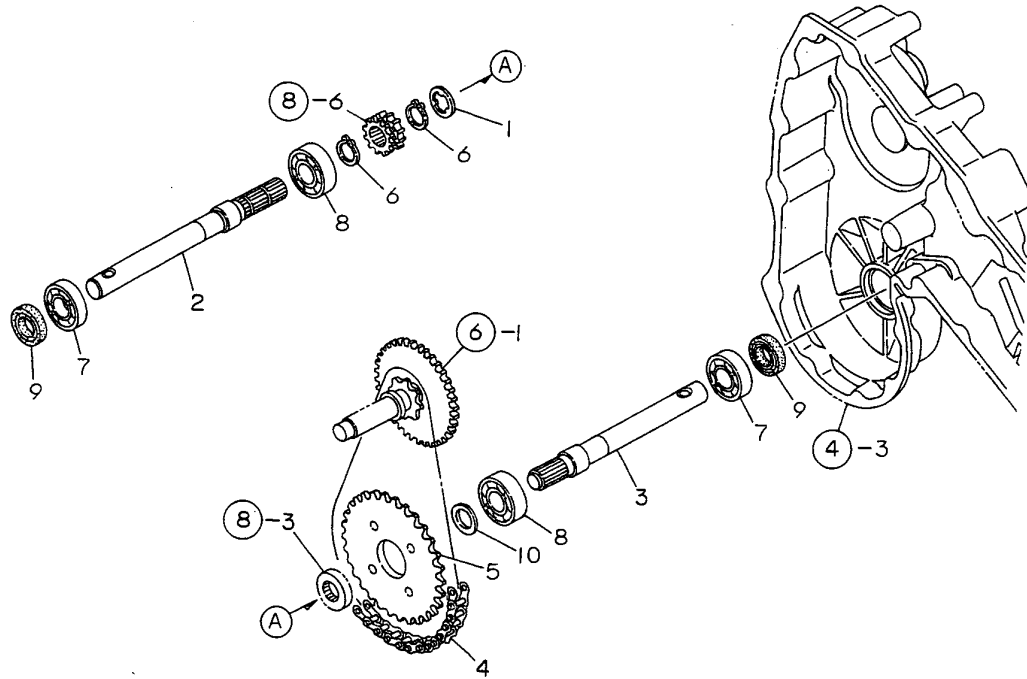

0CNP2-G87900 7. AXLE

(A)=MRT6DXPQ  
(B)=  
(C)=

(D)=  
(E)=  
(F)=

REF.	LEV.	PARTS NO.	DESCRIPTION	Q'TY						I	R
				(A)	(B)	(C)	(D)	(E)	(F)		
1	1	1A1490-20170	THRUST WASHER 30	1							
2	1	1A2170-24000	AXLE L	1							
3	1	1A2170-24010	AXLE R	1							
4	1	1A2170-24050	CHAIN 12.7X46,ROLLER	1							
5	1	1A2170-24130	SPROCKET 30	1							
6	1	22242-000200	CIRCLIP 20	2							
7	1	24101-060044	BALL BEARING 6004	2							
8	1	24101-062044	BALL BEARING	2							
9	1	1E6050-19180	SEAL TC203510,OIL	2							
10	1	1A1105-23200	LINER 30X20.2X1	1							

Fig.8. DIFFERENTIAL

8. DIFFERENTIAL

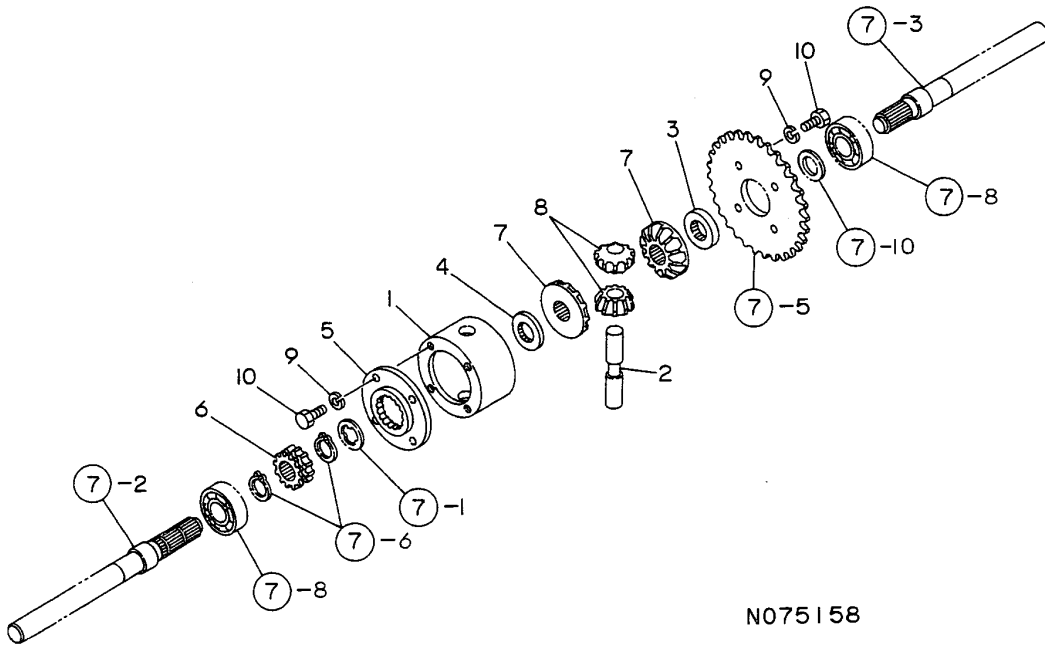

0CNP2-G87900 8. DIFFERENTIAL

(A)=MRT6DXPQ  
(B)=  
(C)=

(D)=  
(E)=  
(F)=

REF.	LEV.	PARTS NO.	DESCRIPTION	Q'TY						I	R
				(A)	(B)	(C)	(D)	(E)	(F)		
1	1	1A2170-24100	CASE,DIFFERENTIAL	1							
2	1	1A2170-24160	SHAFT, DIFF. PINION	1							
3	1	1A2170-24170	COLLAR A,DIFF.	1							
4	1	1A2170-24180	COLLAR B,DIFF.	1							
5	1	1A2170-24200	FLANGE,DIFF.LOCK	1							
6	1	1A2170-24210	GEAR 15,DIFF.LOCK	1							
7	1	194859-31510	GEAR, DIFFERENTIAL	2							
8	1	194859-31820	PINION,DIFFERENTIAL	2							
9	1	22217-080000	SPRING WASHER 8	8							
10	1	26117-080162	BOLT M 8X 16 PLATED	8							

Fig.9. (SPEED) CHANGE

9. (SPEED) CHANGE

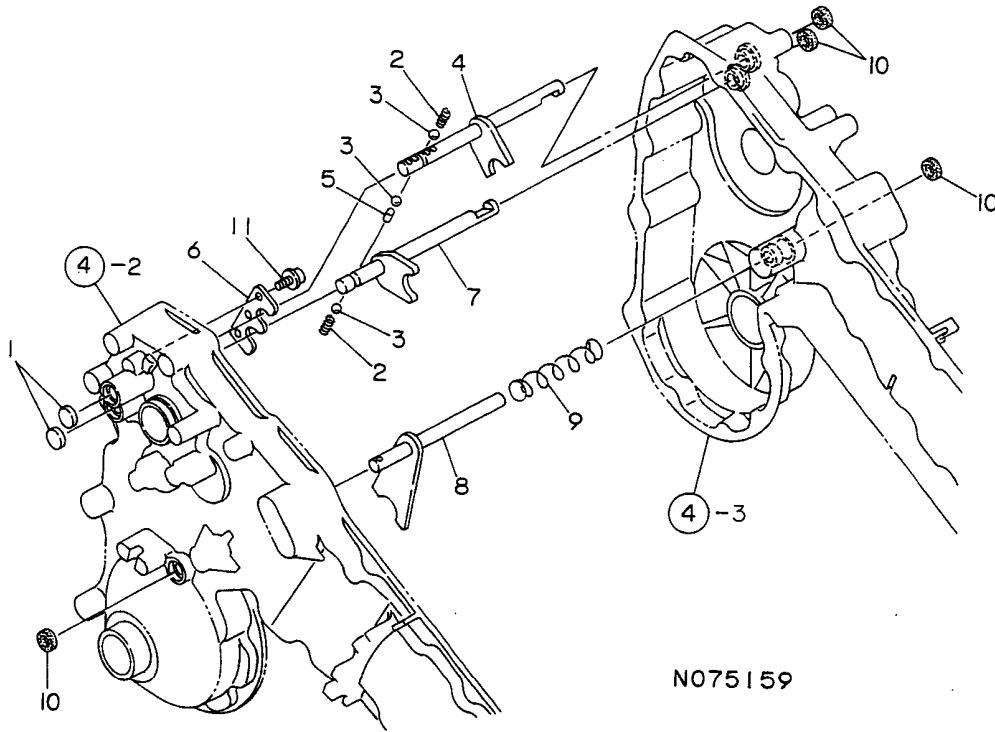

N075159

OCNP2-G87900 9. (SPEED) CHANGE

(A)=MRT6DXPQ

(B)=

(C)=

(D)=

(E)=

(F)=

REF.	LEV.	PARTS NO.	DESCRIPTION	QTY						I	R
				(A)	(B)	(C)	(D)	(E)	(F)		
1	1	1A1750-20431	CAP 18X7,SEAL	2							
2	1	1A2170-27210	SPRING,FORK	2							
3	1	1A1400-26600	STEEL BALL 6	3							
4	1	1A2170-27001	SHAFT A COMPL.,FORK	1							
4-1	1	1A2170-27003	SHAFT A COMPL.,FORK	1							S
(A=F050555)											
5	1	1A1105-27050	PIN,CHG.FORK SHAFT	1							
6	1	1A1950-27101	PLATE,BALL KEEP	1							
7	1	1A2170-27101	SHAFT B COMPL.,FORK	1							
7-1	1	1A2170-27103	SHAFT B COMPL.,FORK	1							S
(A=F050555)											
8	1	1A2170-27150	FORK COMPL.,DIFF.LOCK	1							
9	1	1A2170-27180	SPRING 15X90	1							
10	1	1A1104-28230	OIL SEAL 12184	4							
11	1	1A1750-90200	SCREW 6X12,COLLAR HD	3							

Fig.10. TIRE

10. TIRE

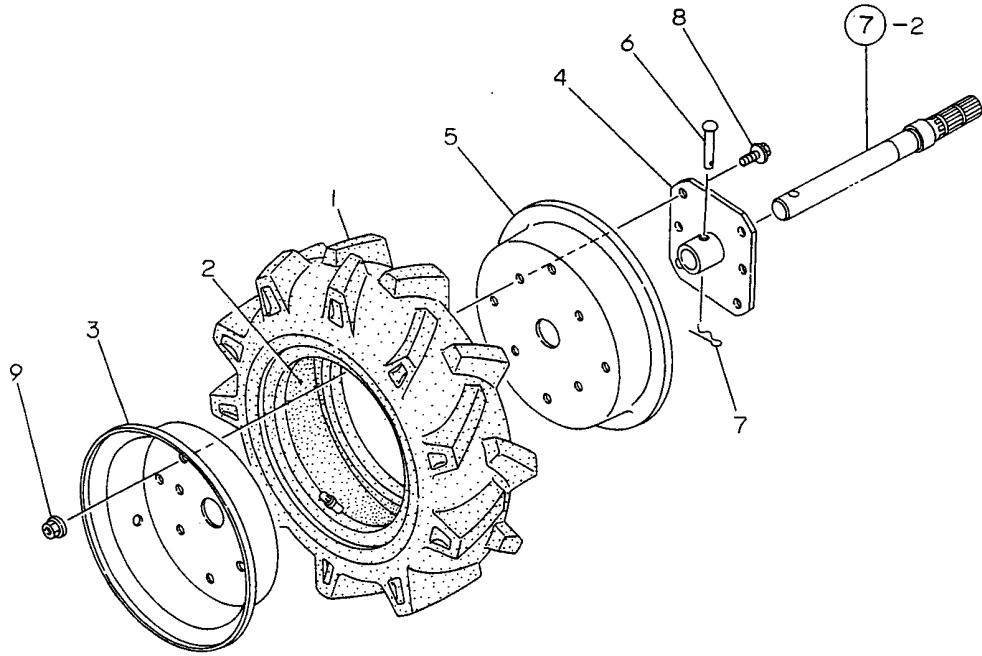

0CNP2-G87900 10. TIRE

(A)=MRT6DXPQ  
(B)=  
(C)=

(D)=  
(E)=  
(F)=

REF.	LEV.	PARTS NO.	DESCRIPTION	QTY						I	R
				(A)	(B)	(C)	(D)	(E)	(F)		
1	1	1A1880-31020	TIRE 3.50-7	2							
2	1	1A1880-31030	TUBE 3.50-7,TIRE	2							
3	1	1A2170-31610	WHEEL,TIRE OUTER	2							
4	1	1A2170-31700	FLANGE 7 COMP.,WHEEL	2							
5	1	1A1105-34010	WHEEL,TIRE INNER	2							
6	1	1A2170-31050	PIN,SHAFT	2							
7	1	1A1540-46020	PIN 8,SNAP	2							
8	1	26107-080182	BOLT M 8X 18 PLATED	8							
9	1	26367-080002	U-NUT M 8	8							

Fig.11. TINE SHAFT & SPADING TINES

11. TINE SHAFT & SPADING TINES

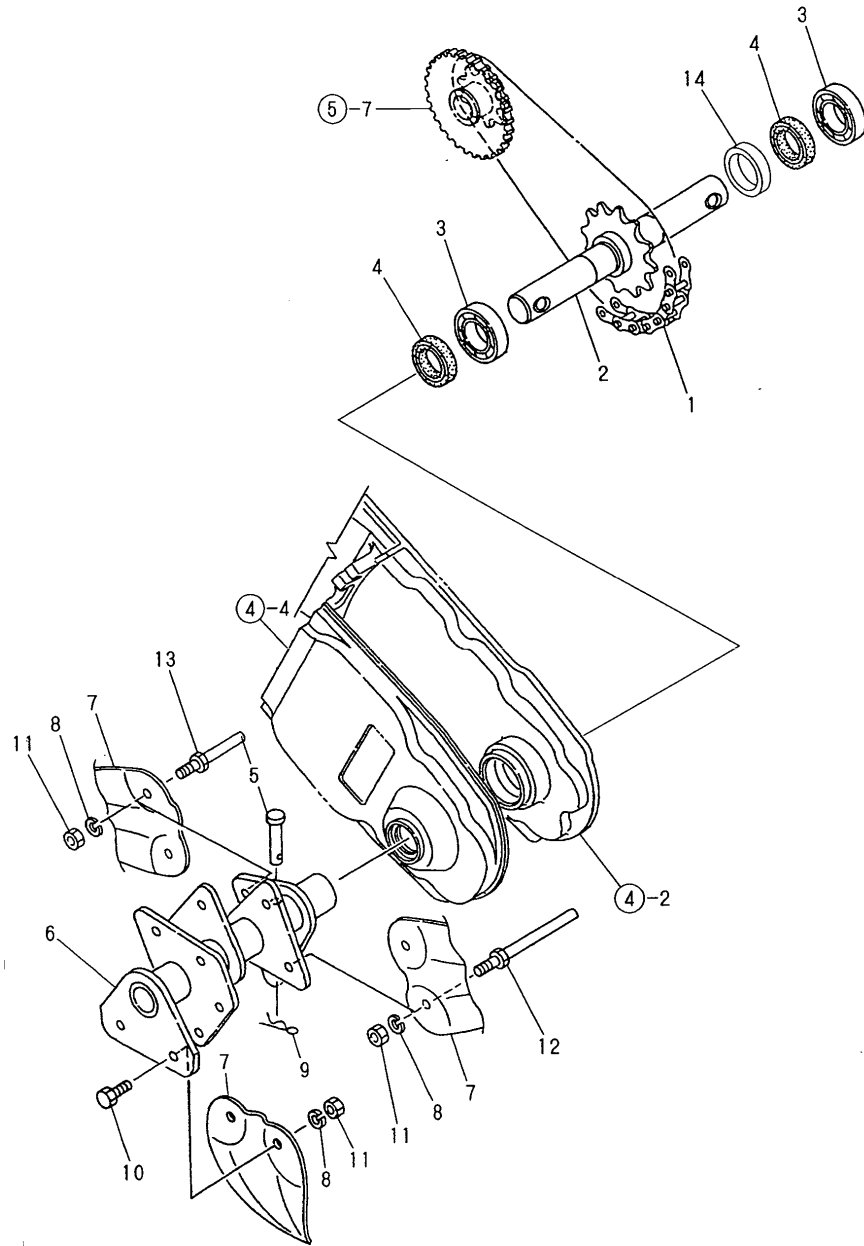

OCNP2-G87900 11. TINE SHAFT & SPADING TINES

(A)=MRT6DXPQ

(B)=

(C)=

(D)=

(E)=

(F)=

REF.	LEV.	PARTS NO.	DESCRIPTION	QTY						I	R
				(A)	(B)	(C)	(D)	(E)	(F)		
1	1	1A2170-42150	CHAIN 15.8X75X62,ROL	1							
2	1	1A2170-42200	SHAFT COMP.,TILLING	1							
2-1	1	1A2170-42201	SHAFT COMP.,TILLING	1							S
(A=F050555)											
3	1	24101-060054	BALL BEARING	2							
3-1	1	24101-060064	BALL BEARING	2							S
(A=F050555)											
4	1	1E6030-34230	SEAL TC254010, OIL	2							
4-1	1	24421-305208	SEAL TC30 52 08, OIL	2							S
(A=F050555)											
5	1	22487-100400	PIN 10X 40	2							
5-1	1	1A2170-43300	SPLIT PIN 10X40	2							S
(A=F038741)											
6	1	1A2170-43051	SHAFT COMP.,TINE	2							
6-1	1	1A2170-43052	SHAFT COMPL.,TINE	2							S
(A=F050555)											
7	1	1A2170-43250	TINE,NOR.ROT./REV.	12							
8	1	22217-080000	SPRING WASHER 8	24							
9	1	22372-100000	SNAP PIN 10	2							
10	1	26116-080202	BOLT M 8X 20 PLATED	20							
11	1	26717-080002	NUT 8	24							
12	1	1A2170-43150	PROTECTOR A,TWINE	2							
12-1	1	1A2170-43151	PROTECTOR A,TWINE	2							S
(A=F050555)											
13	1	1A2170-43200	PROTECTOR B,TWINE	2							
13-1	1	1A2170-43201	PROTECTOR B,TWINE	2							S
(A=F050555)											
14	1	1A2170-42250	COLLAR 30X39.5X13	1							W
(A=F050555)											

Fig.12. TILLING COVER

12. TILLING COVER

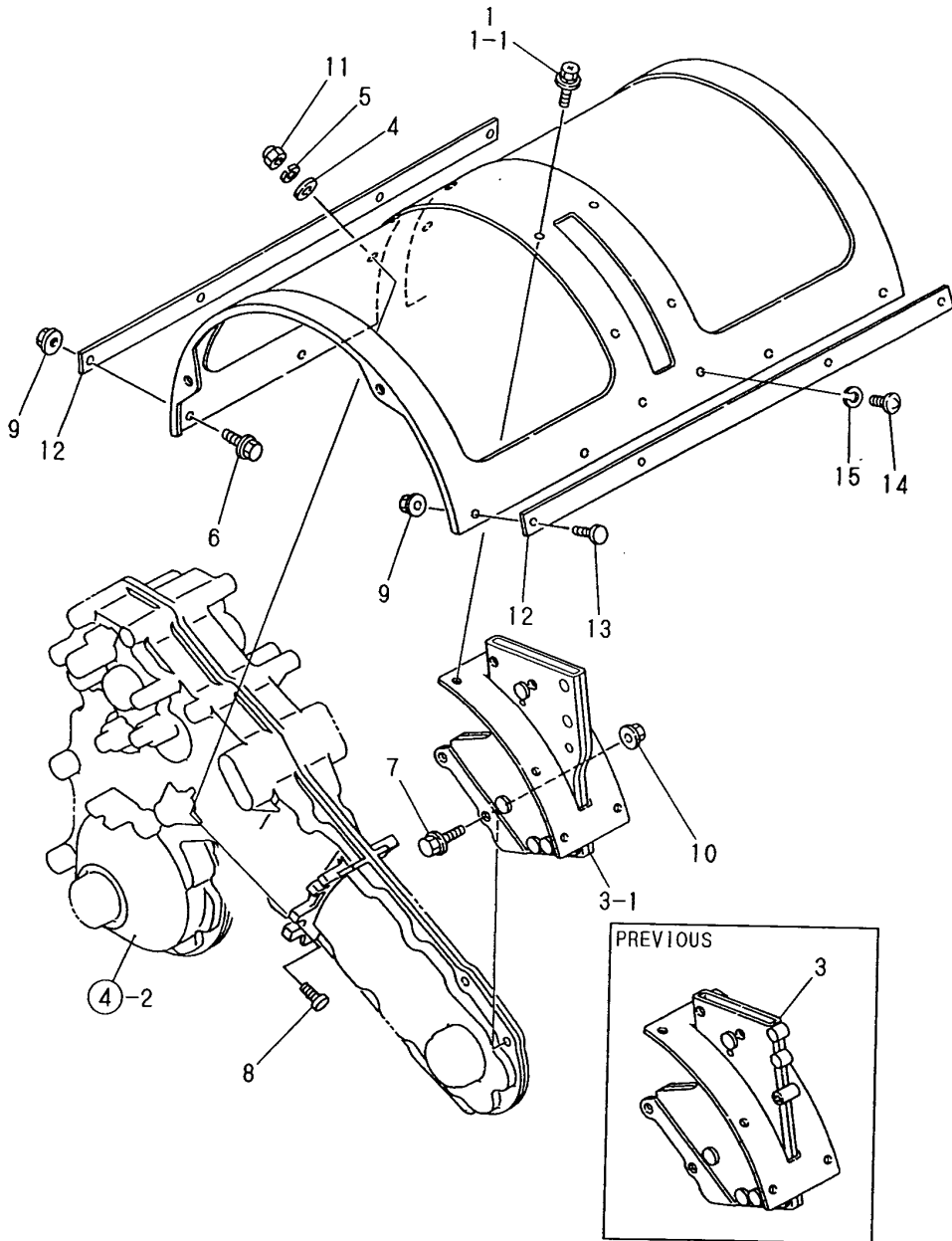

(A)=MRT6DXPQ

(B)=

(C)=

(D)=

(E)=

(F)=

REF.	LEV.	PARTS NO.	DESCRIPTION	QTY						I	R
				(A)	(B)	(C)	(D)	(E)	(F)		
1	1	1D1621-11410	BOLT 6X16,CRH+WSHRS.	6							
1-1	1	1D1621-11410	BOLT 6X16,CRH+WSHRS.	4							K
(A=FXXX)											
2	1	1A2170-44551	COVER,ROTARY	1							
3	1	1A2170-44601	BOX COMP.,TILL.DEPTH	1							
3-1	1	1A2170-44300	BOX COMP.,TILL.DEPTH	1							S
(A=F050555)											
4	1	22137-080000	WASHER 8, POLISHED	4							
5	1	22217-080000	SPRING WASHER 8	4							
6	1	26107-060122	BOLT M 6X 12 PLATED	4							
7	1	26107-080302	BOLT M 8X 30 PLATED	2							
8	1	26167-080252	WELD,BOLT 8* 20	4							
9	1	26367-060002	NUT M 6	8							
10	1	26367-080002	U-NUT M 8	2							
11	1	26657-080002	CAP NUT M 8	4							
12	1	1A2170-44710	PLATE,FRNT REINFORC.	2							
13	1	26167-060142	BOLT M 6X 16 PLATED	4							
14	1	1A1735-55350	SCREW 6X12,PAN HD.	2							W
(A=FXXX)											
15	1	1A1750-90120	WASHER 6,SPRING BLK.	2							W
(A=FXXX)											



Fig.13. AUXILIARY COVER

13. AUXILIARY COVER

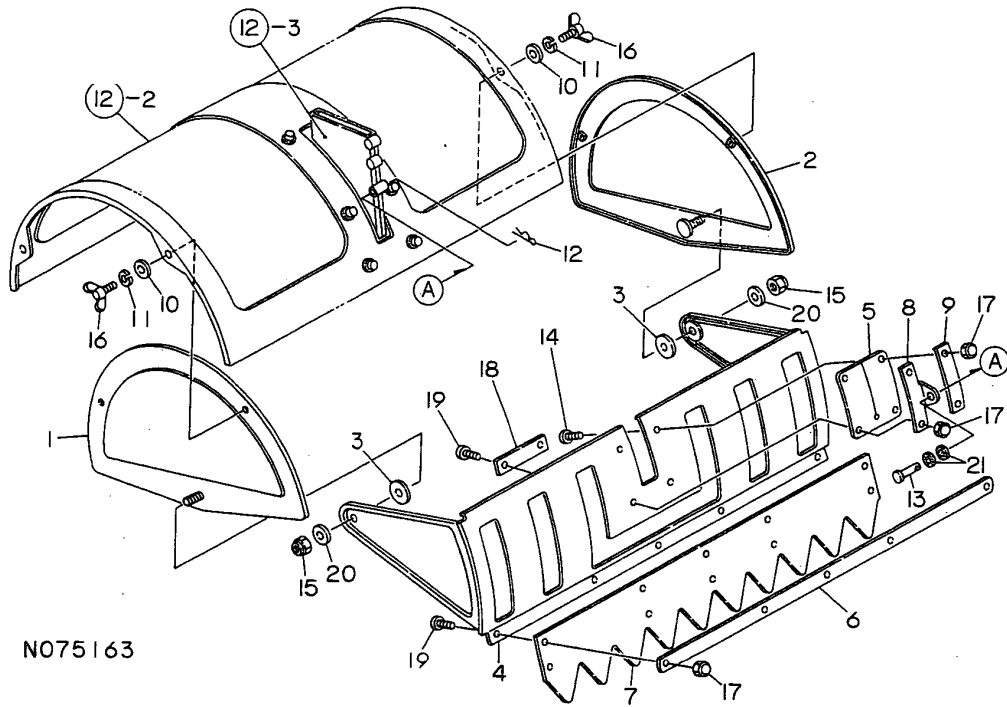

N075163

(A)=MRT6DXPQ

(B)=

(C)=

(D)=

(E)=

(F)=

REF.	LEV.	PARTS NO.	DESCRIPTION	QTY						I	R	
				(A)	(B)	(C)	(D)	(E)	(F)			
1	1	1A2170-44020	COVER I COMP.,SIDE	1								
2	1	1A2170-44040	COVER R COMP.,SIDE	1								
3	1	1A2170-44070	SPACER 10X30X1.5	2								
4	1	1A2170-44101	ROTARY COMP.,MV-RD.	1								
5	1	1A2170-44160	SEAT 73X60,OPERATOR	1								
6	1	1A2170-44171	RETAINER 552,OP.SEAT	1								
7	1	1A2170-44180	SEAT,REAR	1								
8	1	1A2170-44210	RETAINER,SEAT W/STP.	1								
8-1	1	1A2170-44211	RETAINER,SEAT W/STP.	1								N
(A=*1994.11)												
9	1	1A2150-44590	FITTINGS,OPR.SEAT	1								
10	1	22137-080000	WASHER 8, POLISHED	4								
11	1	22217-080000	SPRING WASHER 8	4								
12	1	22360-060000	SNAP PIN 6	1								
13	1	22487-060300	PIN 6X 30	1								
14	1	26167-060122	BOLT 6X12,WELD	2								
15	1	26347-100002	U-NUT M10	2								
16	1	26646-080152	WING BOLT M 8X15	4								
17	1	26657-060002	CAP NUT M 6	9								
18	1	1A2170-44220	REINFORCMT,REAR CVR	1								
19	1	26167-060142	BOLT M 6X 16 PLATED	7								
20	1	22137-100000	WASHER 10,POLISHED	2								
21	1	1A2170-44260	BUSH 6X15X3	2								
22	1	22217-060000	SPRING WASHER 6	4								

Fig.14. HANDLE

14. HANDLE

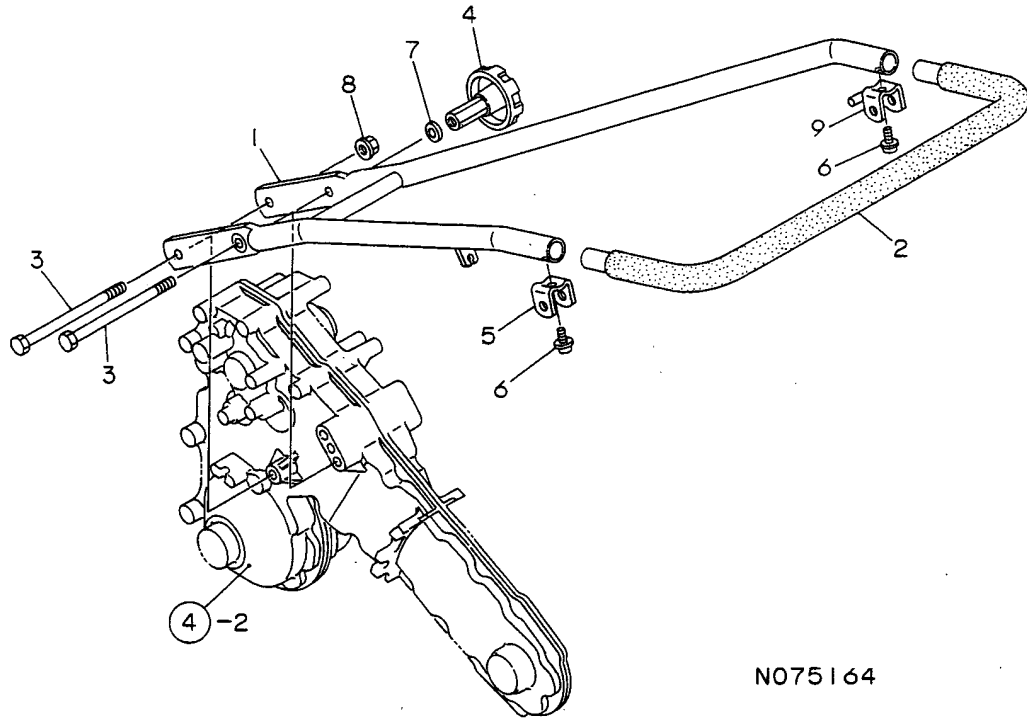

N075164

OCNP2-G87900 14. HANDLE

(A)=MRT6DXPQ  
(B)=  
(C)=

(D)=  
(E)=  
(F)=

REF.	LEV.	PARTS NO.	DESCRIPTION	Q'TY						I	R
				(A)	(B)	(C)	(D)	(E)	(F)		
1	1	1A2170-51501	HANDLE COMPL.	1							
2	1	1A2170-51690	LOOP COMP.,HANDLE	1							
3	1	1A2170-51900	BOLT M10X160				2				
4	1	1A2170-51910	KNOB 10X70,CLAMP	1							
5	1	1A2170-55600	STAY,LEVER MOUNTING	1							
6	1	1A1750-90200	SCREW 6X12,COLLAR HD				2				
7	1	22137-100000	WASHER 10,POLISHED	1							
8	1	26377-100002	U-NUT M10	1							
9	1	1A2170-55500	STAY COMP.,LEVER MTG	1							

Fig.15. HANDLE COVER

15. HANDLE COVER

OCNP2-G87900 15. HANDLE COVER

(A)=MRT6DXPQ

(B)=

(C)=

(D)=

(E)=

(F)=

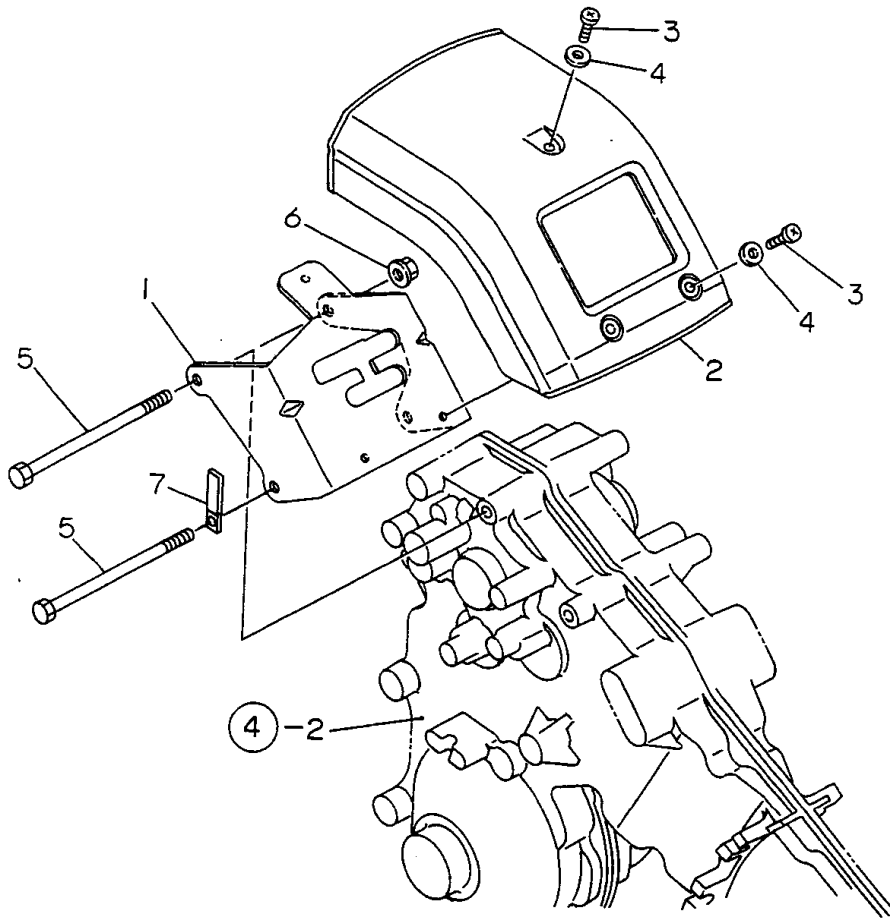

REF.	LEV.	PARTS NO.	DESCRIPTION	Q'TY						I	R
				(A)	(B)	(C)	(D)	(E)	(F)		
1	1	1A2170-51222	GUIDE, CHANGE	1							
1-1	1	1A2170-51223	PLATE, CHANGE GUIDE	1							N
(A=*1995.10)											
2	1	1A2170-53000	COVER, CHANGE	1							
3	1	1A1750-90060	SCREW 5X16, TAPPING	3							
4	1	1A1750-90150	WASHER 5, PLAIN	3							
5	1	26117-081402	BOLT M 8X140 PLATED	2							
6	1	26367-080002	U-NUT M 8	2							
7	1	160820-78710	CLAMP, CORD	1							

Fig.16. CONTROL LEVER

(A)=MRT6DXPQ  
(B)=  
(C)=

(D)=  
(E)=  
(F)=

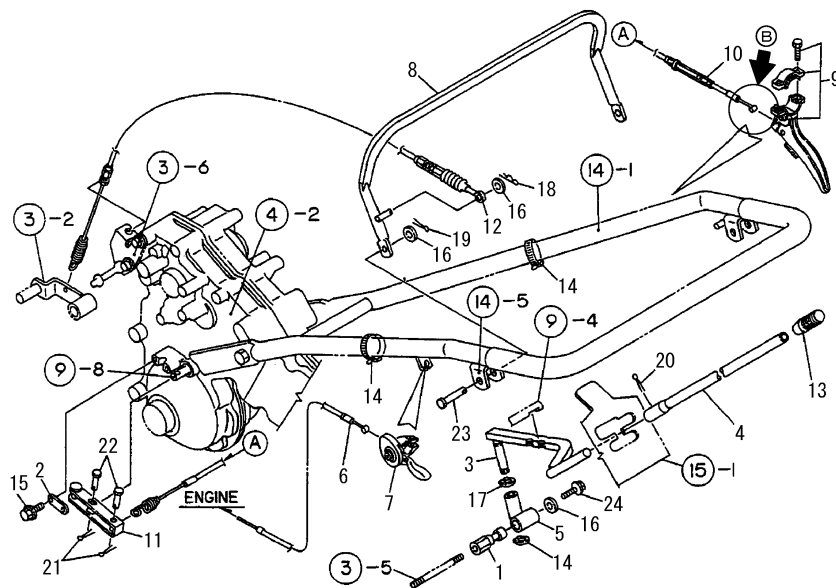
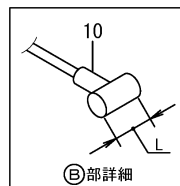

REF.	LEV.	PARTS NO.	DESCRIPTION	QTY						I	R
				(A)	(B)	(C)	(D)	(E)	(F)		
1	1	1A2150-13100	TENSION NUT	1							
2	1	1A1490-50340	SPRING,CHANGE LEVER	1							
3	1	1A2170-55101	LEVER COMP.,CHANGE	1							
3-1	1	1A2170-55102	LEVER COMP.,CHANGE	1							S
(A=F050555)											
4	1	1A2170-55201	LEVER,HAND CHANGE	1							
5	1	1A2170-55250	FULCRUM COMP.,CHANGE	1							
5-1	1	1A2171-55280	FULCRUM COMP.,CHANGE	1							S
(A=F050555)											
6	1	1A1760-40560	WIRE,ACCELERATOR	1							
7	1	1A1402-40750	LEVER,THROTTLE	1							
8	1	1A2170-55701	LEVER COMP.,DEADMAN	1							
9	1	1A2170-55742	LEVER COMP.,DIFF.LOCK	1							
9-1	1	1A2172-55700	LEVER, CLUTCH	1							F 1
(A=FXXXXX)											
10	1	1A2170-55751	WIRE COMP.,DIFF.LOCK	1							
10-1	1	1A2170-55780	WIRE ASSY, LOCK	1							F 2
(A=FXXXXX)											
11	1	1A2150-55800	LEVER COMP.,TILLING	1							
12	1	1A2170-55801	WIRE COMP.,MN.CLUTCH	1							
13	1	1E6570-65750	GRIP,CONT.LEVER BLK.	1							
14	1	1E6102-84970	BAND 140,WIRE LOCK	2							
15	1	1A1750-90200	SCREW 6X12,COLLAR HD	2							
16	1	22137-080000	WASHER 8, POLISHED	4							
17	1	22242-000120	CIRCLIP 12	2							
18	1	22360-080000	SNAP PIN 8	1							
19	1	22411-200160	COTTER PIN 2.0X 16	2							
19-1	1	22417-200160	COTTER PIN 2.0X16	2							N
(A=FXXXX)											
20	1	22411-250250	COTTER PIN 2.5X25	1							
20-1	1	22417-250250	COTTER PIN 2.5X25	1							N
(A=FXXXX)											
21	1	22417-200100	COTTER PIN 2.0X10	2							
22	1	22487-060240	PIN 6X 24	2							
23	1	22487-080450	PIN 8X 45	2							
24	1	26107-080122	BOLT M 8X 12 PLATED	1							

Remarks

(1)REF.NO.9 is metal, NO.9-1 is resin replacement with REF.NO.10-1.  
(2)L=REF.NO.10 15mm, NO.10-1 12mm replacement with REF.NO.9-1.

Fig.17. ENGINE FRAME

17. ENGINE FRAME

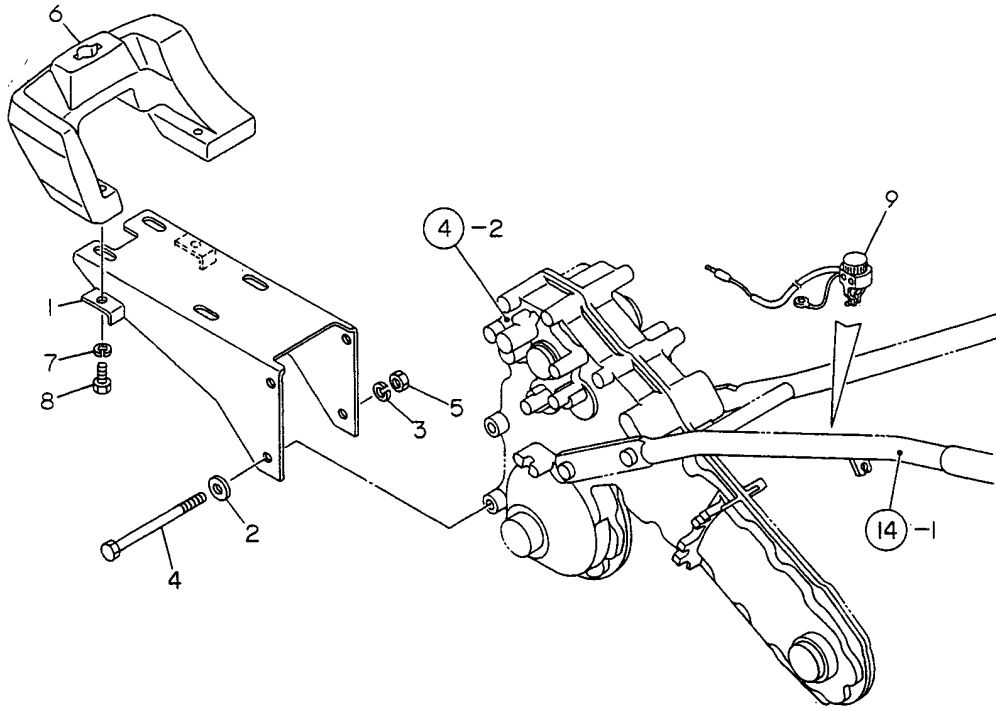

0CNP2-G87900 17. ENGINE FRAME

(A)=MRT6DXPQ  
(B)=  
(C)=

(D)=  
(E)=  
(F)=

REF.	LEV.	PARTS NO.	DESCRIPTION	QTY						I	R	
				(A)	(B)	(C)	(D)	(E)	(F)			
1	1	1A2170-61001	FRAME COMP.,ENGINE	1								
2	1	22137-100000	WASHER 10,POLISHED	2								
3	1	22217-100000	SPRING WASHER 10	2								
4	1	26157-101402	BOLT M10X140	2								
5	1	26737-100002	NUT M10	2								
6	1	1A2170-65000	BUMPER	1								
6-1	1	1A2170-62200	BUMPER	1								N
		(A=FXXX)										
7	1	22217-100000	SPRING WASHER 10	2								
8	1	26117-100202	BOLT M10X 20 PLATED	2								
9	1	1A2170-83201	SWITCH,STOP	1								

Fig.18. BELT COVER

18. BELT COVER

OCNP2-G87900 18. BELT COVER

(A)=MRT6DXPQ  
(B)=  
(C)=

(D)=  
(E)=  
(F)=

REF.	LEV.	PARTS NO.	DESCRIPTION	QTY						I	R
				(A)	(B)	(C)	(D)	(E)	(F)		
1	1	1A2170-13500	COVER COMP.,FRNT.BCK	1							
2	1	1A2170-62000	COVER,BELT	1							
3	1	1A2170-62110	COVER, FLYWHEEL	1							
4	1	1A2000-62300	KNOB,BELT COVER	1							
4-1	1	26367-080002	U-NUT M 8	1							S
(A=FXXX)											
5	1	1A1750-90200	SCREW 6X12,COLLAR HD	3							
6	1	26107-080122	BOLT M 8X 12 PLATED	2							
7	1	22157-080000	WASHER 8	1							W
(A=FXXX)											

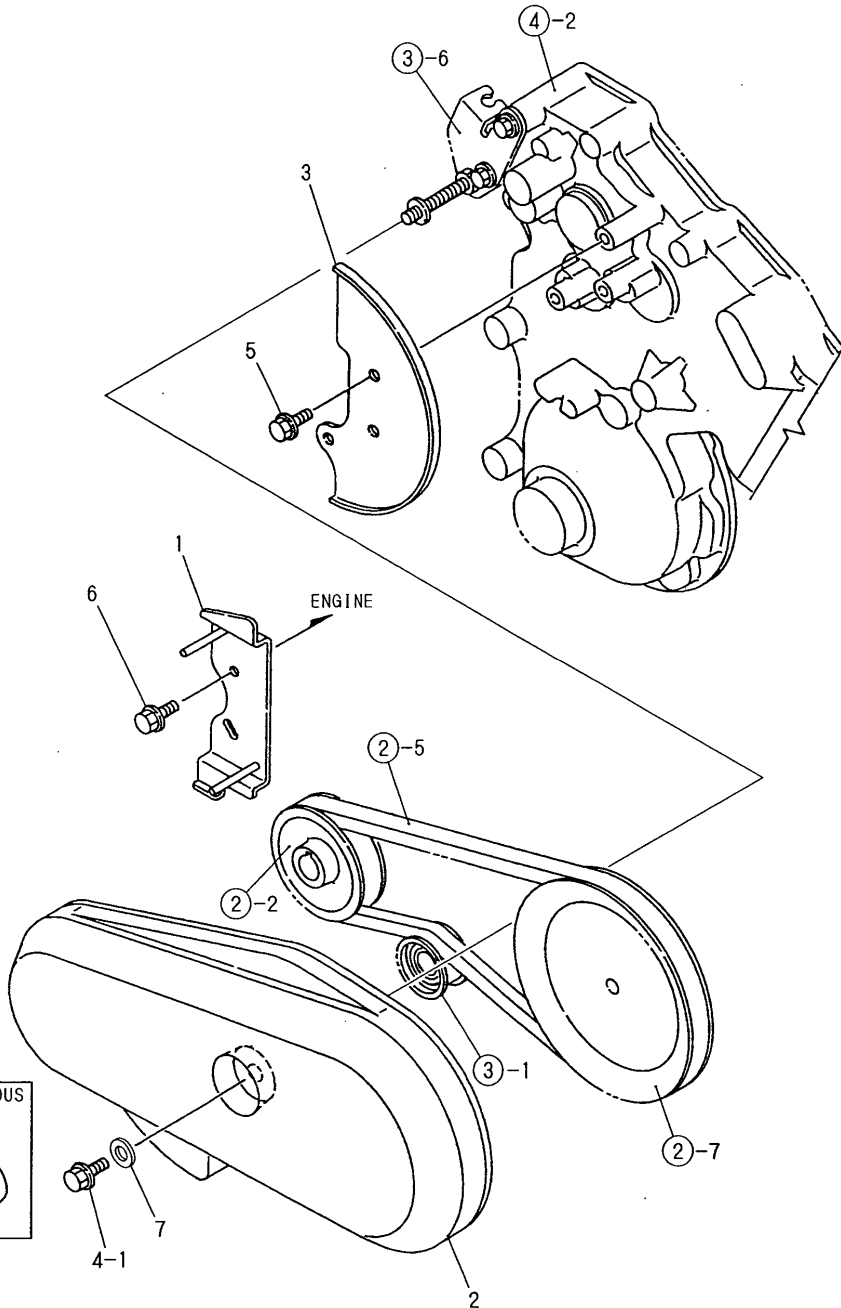
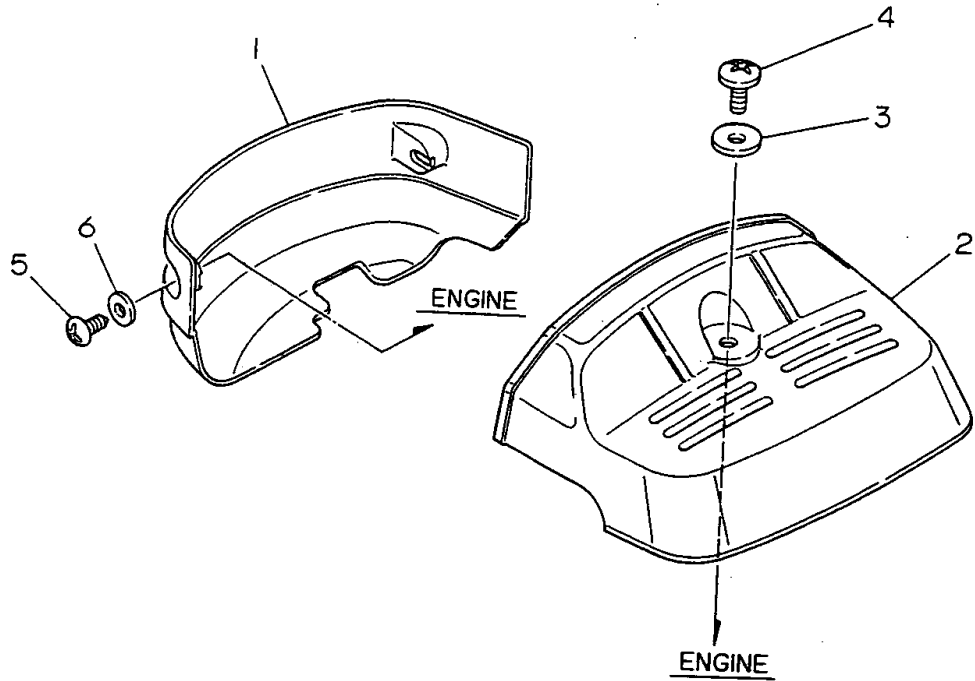

Fig.19. BONNET

19. BONNET



0CNP2-G87900 19. BONNET

(A)=MRT6DXPQ  
(B)=  
(C)=

(D)=  
(E)=  
(F)=

REF.	LEV.	PARTS NO.	DESCRIPTION	Q'TY						I	R
				(A)	(B)	(C)	(D)	(E)	(F)		
1	1	1A2000-64100	MASK, FRONT	1							
2	1	1A2150-64200	COVER, REAR (40	1							
2-1	1	1A2150-64201	COVER,REAR(40W	1							N
(A=*1995.07)											
3	1	1A2000-64210	WASHER 6X19X1.0	1							
4	1	1A2000-64220	SCREW 6X16	1							
5	1	1A1750-90050	SCREW 5X10,TAPPING	2							
6	1	1A1750-90150	WASHER 5,PLAIN	2							

Fig.20. SKID

(A)=MRT6DXPQ  
(B)=  
(C)=

(D)=  
(E)=  
(F)=

20. SKID

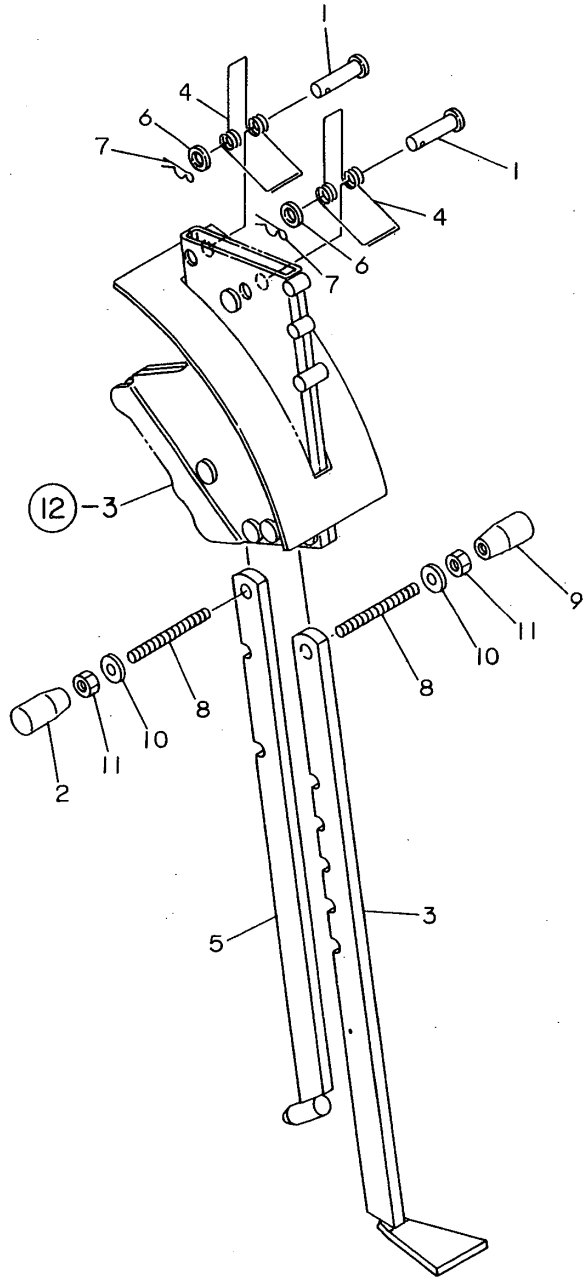

REF.	LEV.	PARTS NO.	DESCRIPTION	QTY						I	R	
				(A)	(B)	(C)	(D)	(E)	(F)			
1	1	1A2170-75160	PIN 10X33,FLAT HEAD	2								
2	1	1D2050-15480	KNOB,LEVER	2								
3	1	1A2170-75052	BAR CMP,TILL.DP.ADJ.	1								
4	1	1A2170-75111	SPRING 46X60X25,TORQ	2								
5	1	1A2170-75251	PREVENTER COMP.,DASH	1								
6	1	22117-100000	WASHER 10	2								
7	1	22360-100000	SNAP PIN 10	2								
8	1	1A2170-75150	SCREW M8X75	2								
9	1	1D2040-15480	KNOB,LEVER	2								
10	1	22137-080000	WASHER 8, POLISHED	4								
11	1	26757-080002	LOCK NUT M 8 PLATED	4								



Fig.21. LABELS

21. LABELS

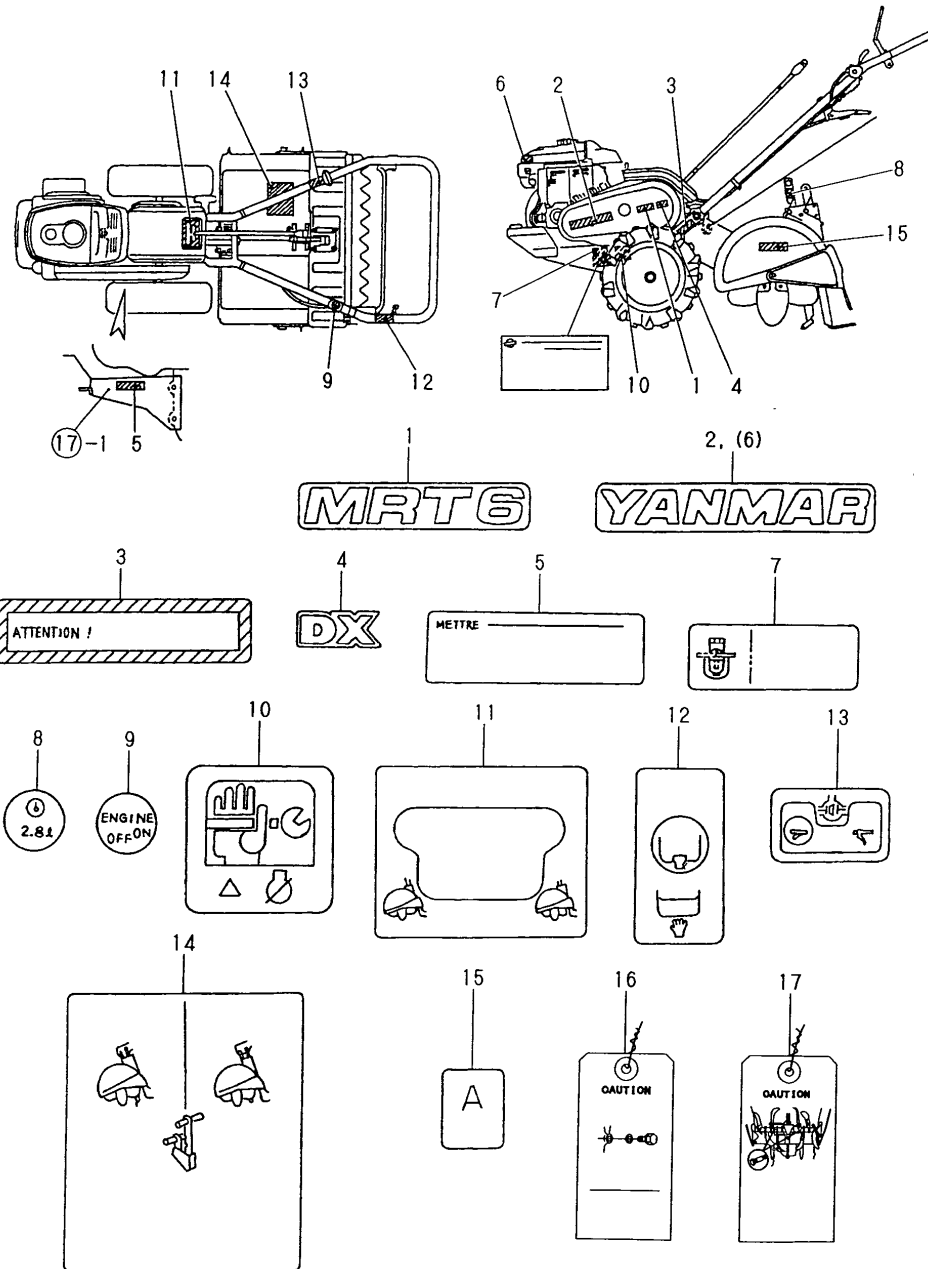

(A)=MRT6DXPQ  
(B)=  
(C)=

(D)=  
(E)=  
(F)=

REF.	LEV.	PARTS NO.	DESCRIPTION	QTY						I	R
				(A)	(B)	(C)	(D)	(E)	(F)		
1	1	1A2170-86000	LABEL, ORNAMENT	1							
2	1	1A2150-86080	LABEL,FRONT MASK	3							
3	1	1A2099-86300	LABEL,CVR.SAFETY	1							
4	1	1A2170-86300	MARK DX	1							
5	1	1A2099-86320	LABEL,CAUTION	1							
6	1	1A2130-86320	LABEL,FUEL TANK	1							
7	1	1A2099-86360	LABEL,FUEL COCK	1							
8	1	1A2170-86860	LABEL,OIL	1							
9	1	1A2170-86890	LABEL EX,STOP SWITCH	1							
10	1	1A2170-86900	LABEL EX,CHECK	1							
11	1	1A2170-86910	LABEL,CHANGE	1							
12	1	1A2170-86920	LABEL EX,MAIN CLUTCH	1							
13	1	1A2170-86940	LABEL EX,DIFF.LOCK	1							
14	1	1A2170-86950	LABEL EX,BACK'G ADJ	1							
15	1	1A2170-86970	LABEL,RESISTANCE BAR	1							
16	1	1A2170-86930	CAP,OIL CAUTION	1							W
		(A=F048963)									
17	1	1A2170-86960	CAP,TN.SHFT.PIN CAUT	1							W
		(A=F038741)									

Fig.22. TOOLS

22. TOOLS

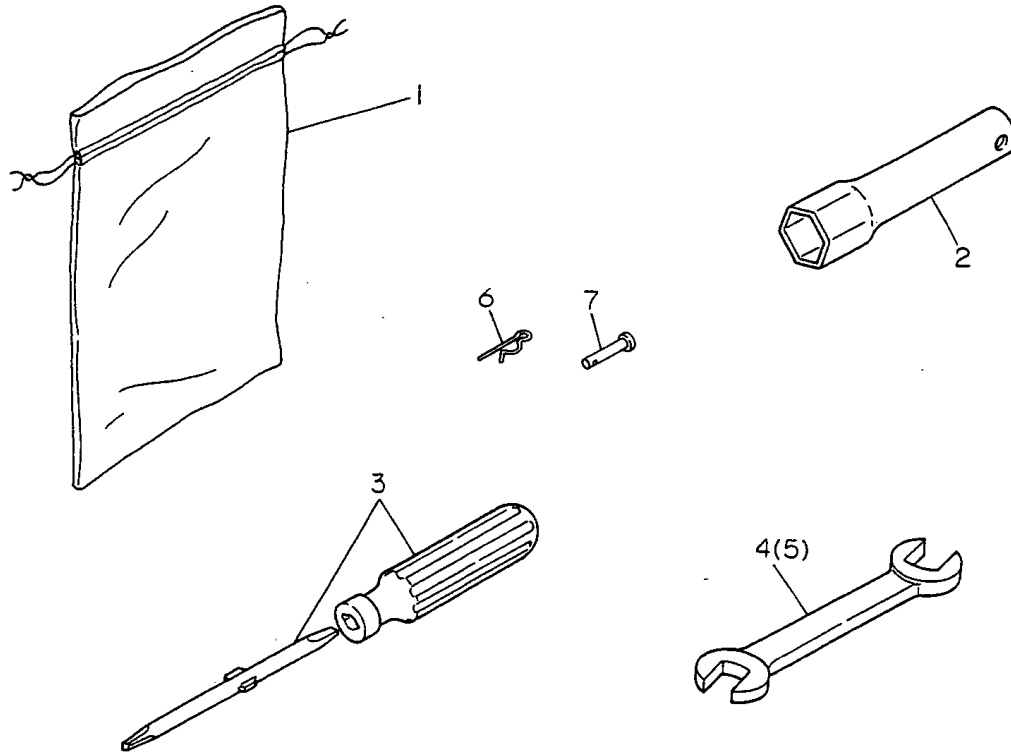

OCNP2-G87900 22. TOOLS

(A)=MRT6DXPQ

(B)=

(C)=

(D)=

(E)=

(F)=

REF.	LEV.	PARTS NO.	DESCRIPTION	QTY						I	R
				(A)	(B)	(C)	(D)	(E)	(F)		
1	1	1A1750-83900	TOOL BAG	1							
2	1	160110-92700	BOX, SPANNER	1							
3	1	160330-92730	SCREWDRIVER (+)	1							
3-1	1	1D2040-87060 (A=FXXX)	SCREWDRIVER,COMBINAT	1							R
4	1	28110-100120	WRENCH 10X12	1							
5	1	28110-120140	WRENCH 12X14	1							
6	1	22372-100000	SNAP PIN 10	1							
7	1	22487-100400	PIN 10X 40	1							
7-1	1	1A2170-43300 (A=F038741)	SPLIT PIN 10X40	1							S

## Part Number Index

All parts are stipulated in the order of part numbers.

(Depending on the area in which the part is used.)

This index will display the location of the part according to each part number.

## PARTS No. INDEX

PARTS No.	Fig.	Ref.No.
160110-92700	22	2
160330-92730	22	3
160820-78710	15	7
194859-31510	8	7
194859-31820	8	8
1A1104-28230	9	10
1A1105-15200	2	8
1A1105-23200	7	10
1A1105-27050	9	5
1A1105-34010	10	5
1A1400-26600	9	3
1A1402-40750	16	7
1A1470-20090	4	1
1A1490-20170	7	1
1A1490-50340	16	2
1A1540-46020	10	7
1A1735-23250	5	8
	6	3
1A1735-55350	12	14
1A1750-20431	9	1
1A1750-83900	22	1
1A1750-90050	19	5
1A1750-90060	15	3
1A1750-90120	12	15
1A1750-90150	15	4
	19	6
1A1750-90200	9	11
	14	6
	16	15
	18	5
1A1760-40560	16	6
1A1880-31020	10	1
1A1880-31030	10	2
1A1950-27101	9	6
1A2000-23251	5	10
1A2000-62300	18	4
1A2000-64100	19	1
1A2000-64210	19	3
1A2000-64220	19	4
1A2001-21250	4	10 -1
1A2099-86300	21	3
1A2099-86320	21	5
1A2099-86360	21	7
1A2120-13120	3	4
1A2130-86320	21	6
1A2150-13100	3	3
	16	1
1A2150-44590	13	9
1A2150-55800	16	11
1A2150-64200	19	2

PARTS No.	Fig.	Ref.No.
1A2150-64201	19	2 -1
1A2150-86080	21	2
1A2160-12000	2	2
1A2170-13000	3	2
1A2170-13150	3	5
1A2170-13300	2	7
1A2170-13400	2	5
1A2170-13500	18	1
1A2170-13600	3	6
1A2170-21010	4	2
1A2170-21110	4	3
1A2170-21150	4	4
1A2170-21200	4	5
1A2170-21250	4	13
1A2170-21260	4	14
1A2170-23000	5	1
1A2170-23011	5	2
1A2170-23021	5	3
1A2170-23101	5	6
1A2170-23102	5	6 -1
1A2170-23141	5	7
1A2170-23170	5	8 -1
1A2170-23200	6	1
1A2170-23201	6	1 -1
1A2170-23231	6	2
1A2170-23261	6	4
1A2170-23280	6	5
1A2170-23282	6	5 -1
1A2170-23290	6	6
1A2170-24000	7	2
1A2170-24010	7	3
1A2170-24050	7	4
1A2170-24100	8	1
1A2170-24130	7	5
1A2170-24160	8	2
1A2170-24170	8	3
1A2170-24180	8	4
1A2170-24200	8	5
1A2170-24210	8	6
1A2170-27001	9	4
1A2170-27003	9	4 -1
1A2170-27101	9	7
1A2170-27103	9	7 -1
1A2170-27150	9	8
1A2170-27180	9	9
1A2170-27210	9	2
1A2170-31050	10	6
1A2170-31610	10	3
1A2170-31700	10	4
1A2170-42150	11	1

PARTS No.	Fig.	Ref.No.
1A2170-42200	11	2
1A2170-42201	11	2 -1
1A2170-42250	11	14
1A2170-43051	11	6
1A2170-43052	11	6 -1
1A2170-43150	11	12
1A2170-43151	11	12 -1
1A2170-43200	11	13
1A2170-43201	11	13 -1
1A2170-43250	11	7
1A2170-43300	11	5 -1
	22	7 -1
1A2170-44020	13	1
1A2170-44040	13	2
1A2170-44070	13	3
1A2170-44101	13	4
1A2170-44160	13	5
1A2170-44171	13	6
1A2170-44180	13	7
1A2170-44210	13	8
1A2170-44211	13	8 -1
1A2170-44220	13	18
1A2170-44260	13	21
1A2170-44300	12	3 -1
1A2170-44551	12	2
1A2170-44601	12	3
1A2170-44710	12	12
1A2170-51222	15	1
1A2170-51223	15	1 -1
1A2170-51501	14	1
1A2170-51690	14	2
1A2170-51900	14	3
1A2170-51910	14	4
1A2170-53000	15	2
1A2170-55101	16	3
1A2170-55102	16	3 -1
1A2170-55201	16	4
1A2170-55250	16	5
1A2170-55500	14	9
1A2170-55600	14	5
1A2170-55701	16	8
1A2170-55742	16	9
1A2170-55751	16	10
1A2170-55780	16	10 -1
1A2170-55801	16	12
1A2170-61001	17	1
1A2170-62000	18	2
1A2170-62110	18	3
1A2170-62200	17	6 -1
1A2170-65000	17	6

PARTS No.	Fig.	Ref.No.
1A2170-75052	20	3
1A2170-75111	20	4
1A2170-75150	20	8
1A2170-75160	20	1
1A2170-75251	20	5
1A2170-83201	17	9
1A2170-86000	21	1
1A2170-86300	21	4
1A2170-86860	21	8
1A2170-86890	21	9
1A2170-86900	21	10
1A2170-86910	21	11
1A2170-86920	21	12
1A2170-86930	21	16
1A2170-86940	21	13
1A2170-86950	21	14
1A2170-86960	21	17
1A2170-86970	21	15
1A2171-13400	2	5 -1
1A2171-21020	4	2 -1
1A2171-21120	4	3 -1
1A2171-21300	4	7 -1
1A2171-21350	4	8 -1
1A2171-23050	5	1 -1
1A2171-55280	16	5 -1
1A2172-55700	16	9 -1
1D1140-11420	1	1
	2	1
1D1621-11410	12	1
		1 -1
1D2040-15480	20	9
1D2040-87060	22	3 -1
1D2050-15480	20	2
1E4060-10040	3	1
1E4060-74090	5	9
	6	9
1E6030-34230	11	4
1E6050-19180	7	9
1E6102-84970	16	14
1E6570-65750	16	13



**YANMAR CO.,LTD.**